

BEST ONE

SUBMERSIBLE ELECTRIC PUMPS

in AISI 304



BEST ONE



BEST ONE VOX

Submersible electric pumps for clean water with hydraulics in AISI 304 stainless steel.

APPLICATIONS

- Draining basements, garages, cellars or places subject to flooding
- Supplying garden fountains
- Easy emptying of tanks and reservoirs

TECHNICAL DETAILS

- Standard mechanical seal
- New and revised design and shape
- Technologically and mechanically optimised
- Their versatility means they can be used in fixed or mobile installations
- Equipped with 5 m of H05 RN-F power supply cable for indoor use (10 m for outdoor use), with or without float

TECHNICAL DATA

- Maximum immersion: 5 m
- Maximum temperature of the liquid: 50°C
- Max. solids size for passage:
 - 10 mm
 - 20 mm for the VOX version (Vortex)
- Asynchronous motor, 2 poles
- Class of insulation F
- IP68 Protection rating
- 230V ±10%, 50Hz single phase voltage, 400 ±10%, 50Hz three phase voltage
- Discharge connection: G1¼

MATERIALS

- External casing, impeller, filter, motor cover, seal housing disc and motor case in AISI 304
- Shaft in AISI 303
- Mechanical seal in Carbon/Ceramic/NBR

SPECIAL VERSIONS

- MS version with magnetic float
- MA version with float
- VORTEX version (VOX)

ACCESSORIES (on request)

- 1¼ outlet connector and relative clamp
- Minimum suction device up to 3 mm (for BEST ONE only)

For other accessories and control panels see from page 66

PERFORMANCE CURVES (according to ISO 9906 Attachment A)

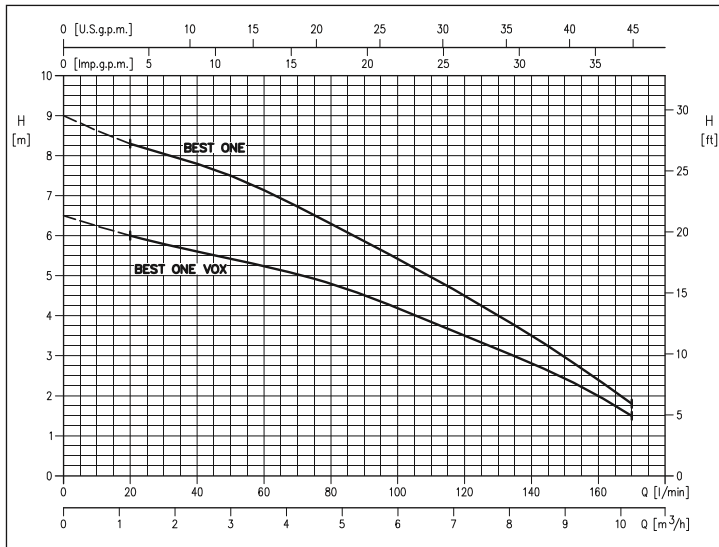

IDENTIFICATION CODE

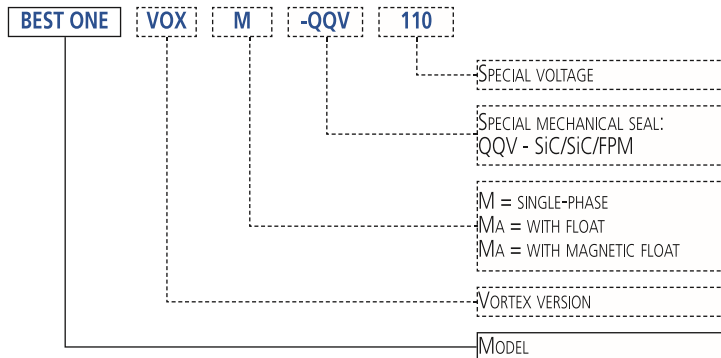

SUBMERSIBLE ELECTRIC PUMPS

in AISI 304

PERFORMANCE TABLE

Single phase 230V	Model	Three phase 400V	P ₂		Capacitor		Ab. Curr.		Q=Flow rate							
			[HP]	[kW]	μF	Vc	[A]	[A]	l/min	20	40	80	120	160	170	
									H=Head [m]							
									2,3	0,8	8,3	7,8	6,3	4,5	2,4	1,8
									2,2	0,8	6,0	5,6	4,8	3,5	2,0	1,5
BEST ONE M	BEST ONE		0,33	0,25	8	450										
BEST ONE VOX M	BEST ONE VOX		0,33	0,25	8	450										

DIMENSIONS

BEST ONE MA / BEST ONE VOX MA

BEST ONE MS

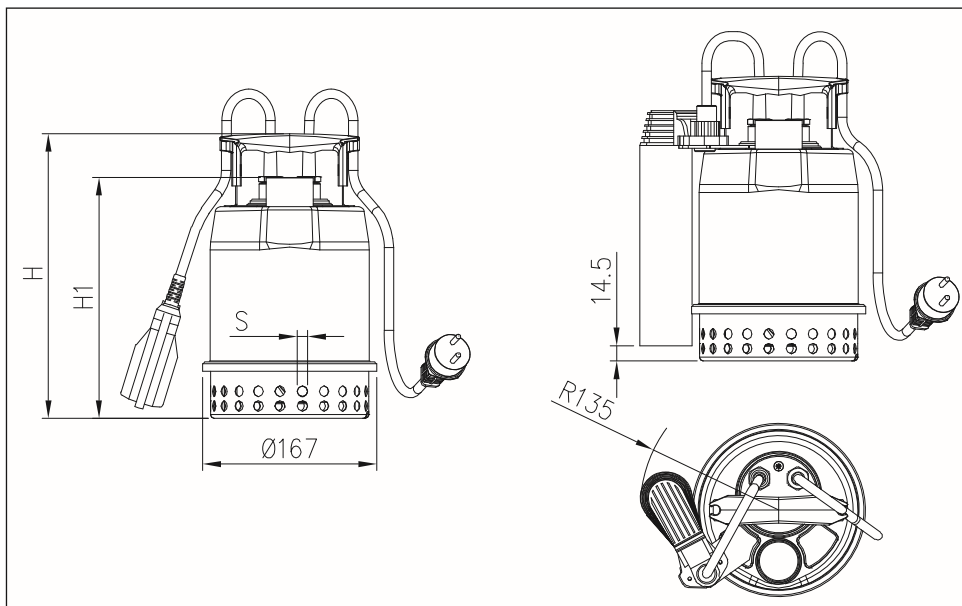

DIMENSIONS TABLE

Model	Dimensions [mm]			Weight [kg]
	H	H1	S	
BEST ONE	273	231	10	4,3
BEST ONE M	273	231	10	4,4
BEST ONE MA	273	231	10	4,6
BEST ONE MS	273	231	10	4,8
BEST ONE VOX	304	262	20	4,4
BEST ONE VOX M	304	262	20	4,5
BEST ONE VOX MA	304	262	20	4,7

SECTIONAL VIEW

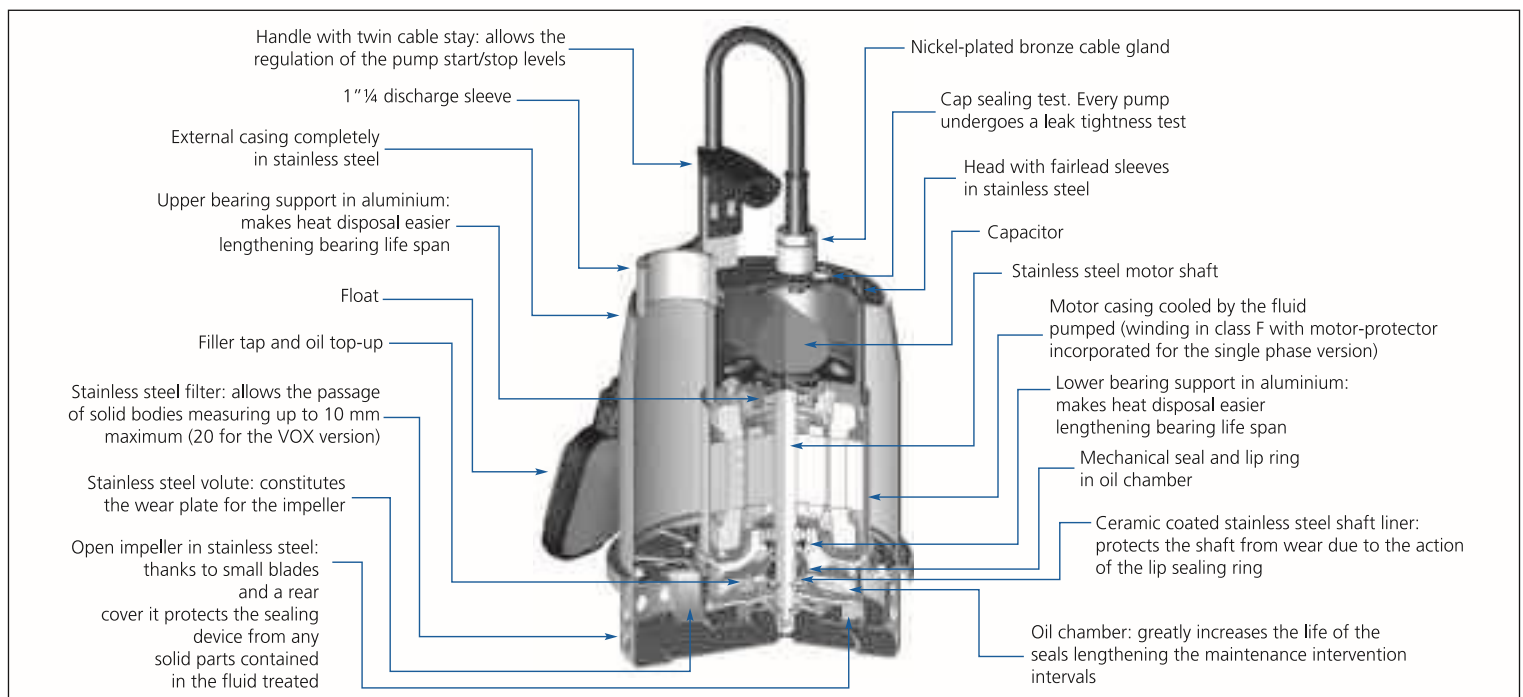

SUBMERSIBLE ELECTRIC PUMPS

in AISI 304

INSTALLATION

BEST ONE MA / BEST ONE VOX MA

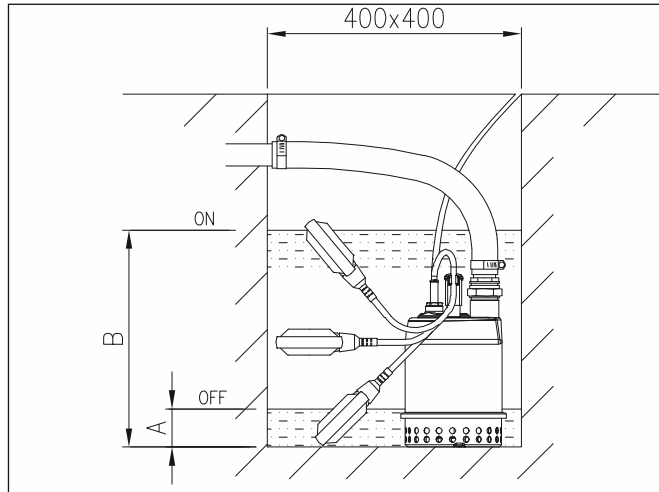

BEST ONE MS

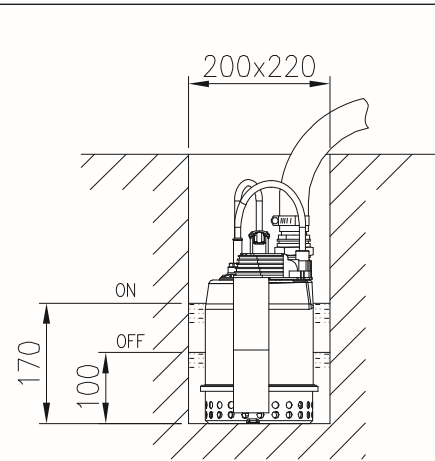

INSTALLATION TABLE

Model	A	B
BEST ONE MA	110	305
BEST ONE VOX MA		330

OPTIONAL

MINIMUM SUCTION DEVICE



The minimum suction device allows to suck the liquid up to 3 mm from the ground (starting from at least 10 mm).

It is easily mounted on the BEST ONE, by simply pressing.